



Shock Sensor

The piezoelectric element produces a voltage which is proportional to the acceleration of an impact or a vibration to which it is exposed. The shock sensor utilizes piezoelectric ceramics to convert the energy of impact into a proportional electrical signal. The piezoelectric shock sensor uses a "unimorph" diaphragm which consists of a piezoelectric ceramic disk laminated to a metal disk. The diaphragm is supported along its circumference in a housing. The sensor features compact, lightweight design, and is suitable for a wide range of applications requiring impact and vibration sensing.

Features:

1. Compact, lightweight design.
2. High sensitivity assures it picks up even microlevel impact and vibration.
3. Rugged construction survive impact and vibration stresses.
4. Requires no bias voltage.

Applications:

1. Car burglar sensors on doors.
2. Intruder sensors at windows or doors.
3. Burglar alarms for showcases and safes.
4. Vibration sensors for car audio equipment

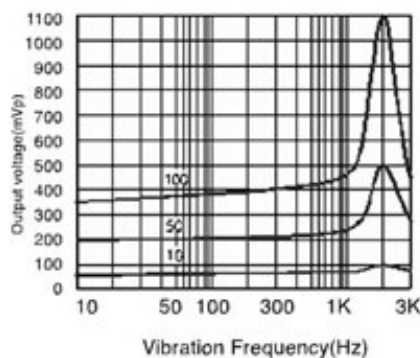
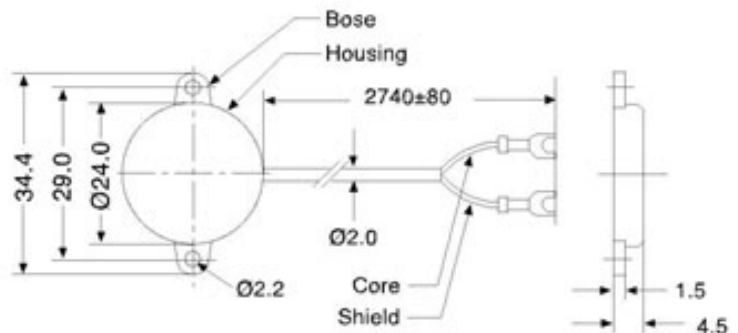

Frequency response is nearly flat at vibration frequency up to 1kHz

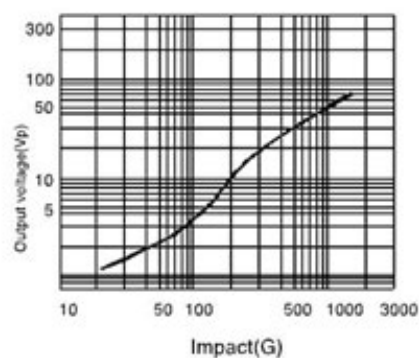

Output voltage is nearly proportional to the acceleration of impact

Electrical Specification	
Output Voltage	40mVp/G typ. (25°C; 10Hz – 1kHz)
Capacitance	12nF±30% (25°C; 1kHz)
Insulation Resistance	100 MΩ min.
Housing Material	PC
Operating Temp. Range	-20°C....70°C
Storage Temp. Range	-30°C....80°C
Weight	24.6 gr.